



EC-600/120



- Ideal for refurbishments, small works and installation on a tubular scaffolding.
 - Maximum safety and robustness.
 - Galvanized cage and columns.
 - Easy installation.
 - Triangular mast compatible with: EC-HA-500/120, ECP 500/120 and CAMAC-1500.
- *Idéal pour la réhabilitation, les petits travaux et le montage d'échafaudages tubulaires.*
 - *Sécurité et robustesse maximales.*
 - *Finitions galvanisées.*
 - *Installation facile.*
 - *Mât triangulaire compatible avec: EC-HA-500/120, ECP-500/120 et CAMAC-1500.*



Mechanical centrifugal emergency brake
Frein de secours centrifuge mécanique

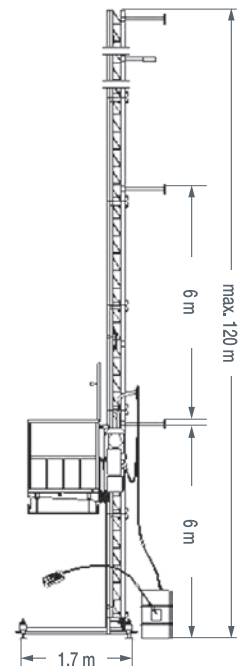
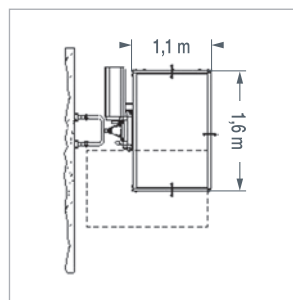
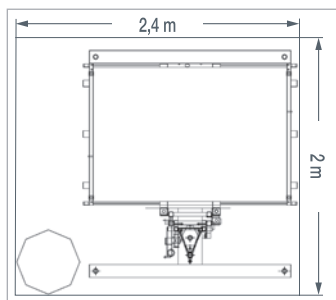

SPECIFICATIONS	CARACTÉRISTIQUES	THREE-PHASE TRIPHASÉ	SINGLE-PHASE MONOPHASÉ	THREE-PHASE TRIPHASÉ	SINGLE-PHASE MONOPHASÉ
Max. height	<i>Hauteur maximale</i>	120 m	120 m	Kg 600	Kg 300
Distance between ties	<i>Distance entre ancrages</i>	6 m	6 m		
Capacity	<i>Charge utile</i>	600 Kg	300 Kg	380 V	220 V
Platform length	<i>Longueur plate-forme</i>	1600 mm	1600 mm		
Platform width	<i>Largeur plate-forme</i>	1100 mm	1100 mm	5,5	2,2
Voltage	<i>Tension</i>	380 V - 50 Hz	220 V - 50 Hz	Kw	Kw
Climbing speed	<i>Vitesse de levage</i>	20 m/min	15 m/min		
Motor power	<i>Puissance du moteur</i>	5,5 Kw	2,2 Kw		