



## MONTACARGAS A CREMALLERA MATERIAL HOISTS

# CAMAC MCM

### CAMAC SMART



- El nuevo CAMAC SMART es el primer montacargas a cremallera creado específicamente para trabajar con un andamio tubular. Su diseño, compacto y ligero y sus reducidas dimensiones, permiten su fácil instalación en el andamio.
  - Este nuevo montacargas está ideado para poderse manipular y montar manualmente, gracias a la ligereza del grupo base y la posibilidad de desmontar las cestas.
  - Medidas exteriores para cesta pequeña (hueco 1500 x 700 mm.)
- The new CAMAC SMART is the first rack & pinion hoist created specifically to work with scaffolding systems. Its light and compact design, along with its reduced dimensions allow its easy installation inside the scaffold.*
  - This new rack & pinion hoist has been manufactured to be installed and moved by hand, thanks to the lightness of the base equipment and the possibility to dismantle the baskets.*
  - External sizes for small basket (hole of 1500 x 700 mm.)*



Cesta interior  
Inner basket



Accesorio para transporte del andamio  
Accessory for scaffold transport



Cesta exterior  
Outer basket



Freno de emergencia centrífugo-mecánico  
Mechanical centrifugal emergency brake

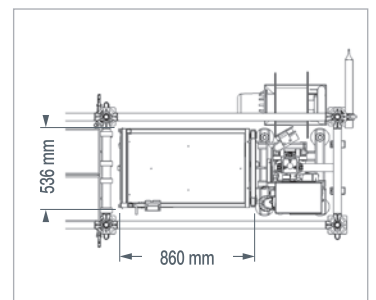
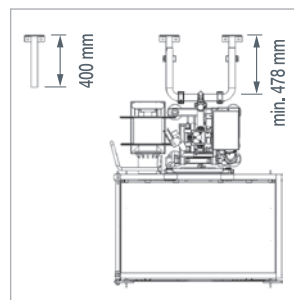
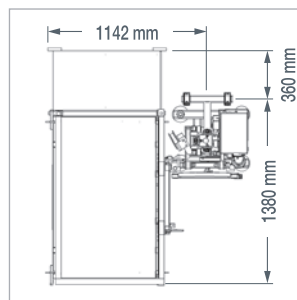
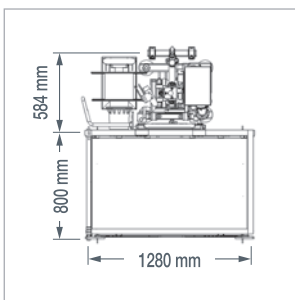

#### CARACTERÍSTICAS

#### SPECIFICATIONS

#### MONTAJE INTERIOR INNER INSTALLATION

#### MONTAJE EXTERIOR OUTER INSTALLATION

#### CAMAC SMART

Altura máxima	Maximun height	45 m	60 m
Distancia entre anclajes	Distance between ties	3 m	3 m
Carga útil	Capacity	250 Kg	250 Kg
Dimensiones cesta	Basket dimensions	822 x 470 mm	1200 x 715 mm
Tensión	Voltage	220 V - 50 Hz	220 V - 50 Hz
Velocidad de subida	Climbing speed	15 m/min	15 m/min
Hueco del andamio	Scaffold hole	1500 x 700 mm	.
Potencia del motor	Motor power	2,2 Kw	2,2 Kw

↑ Kg  
250

⚡  
220 V

2,2  
Kw