



MONTACARGAS A CREMALLERA MATERIAL HOISTS

CAMAC MOM

EC-600/120



- Ideal para rehabilitación, obra pequeña y montaje de andamio tubular.
- Máxima seguridad y robustez.
- Acabados galvanizados.
- Fácil instalación.
- Columna Triangular compatible con: EC-HA-500/120, ECP 500/120 y CAMAC-1500.
- *Ideal for refurbishments, small works and installation on a tubular scaffolding.*
- *Maximum safety and robustness.*
- *Galvanized cage and columns.*
- *Easy installation.*
- *Triangular mast compatible with: EC-HA-500/120, ECP 500/120 and CAMAC-1500.*



Freno de emergencia centrífugo-mecánico
Mechanical centrifugal emergency brake

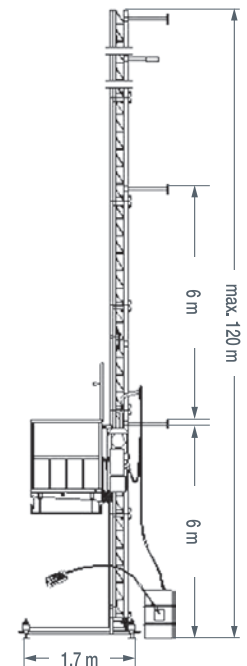
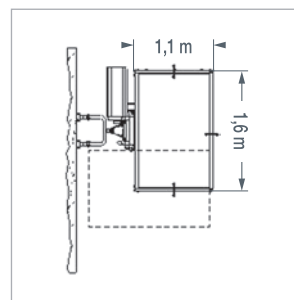
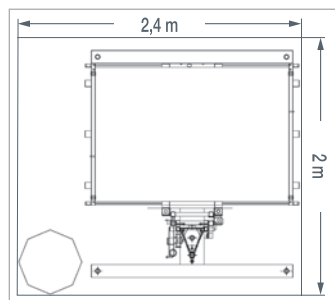

CARACTERÍSTICAS	SPECIFICATIONS	TRIFÁSICO THREE-PHASE	MONOFÁSICO SINGLE-PHASE	TRIFÁSICO THREE-PHASE	MONOFÁSICO SINGLE-PHASE
Altura máxima	<i>Max. height</i>	120 m	120 m	Kg 600	Kg 300
Distancia entre anclajes	<i>Distance between ties</i>	6 m	6 m	380 V	220 V
Carga útil	<i>Capacity</i>	600 Kg	300 Kg	5,5 Kw	2,2 Kw
Largo plataforma	<i>Platform length</i>	1600 mm	1600 mm		
Ancho plataforma	<i>Platform width</i>	1100 mm	1100 mm		
Tensión	<i>Voltage</i>	380 V - 50 Hz	220 V - 50 Hz		
Velocidad de subida	<i>Climbing speed</i>	20 m/min	15 m/min		
Potencia del motor	<i>Motor power</i>	5,5 Kw	2,2 Kw		